

Chiksan® - Top Closed System - Loading Arms

Model 375 / 475

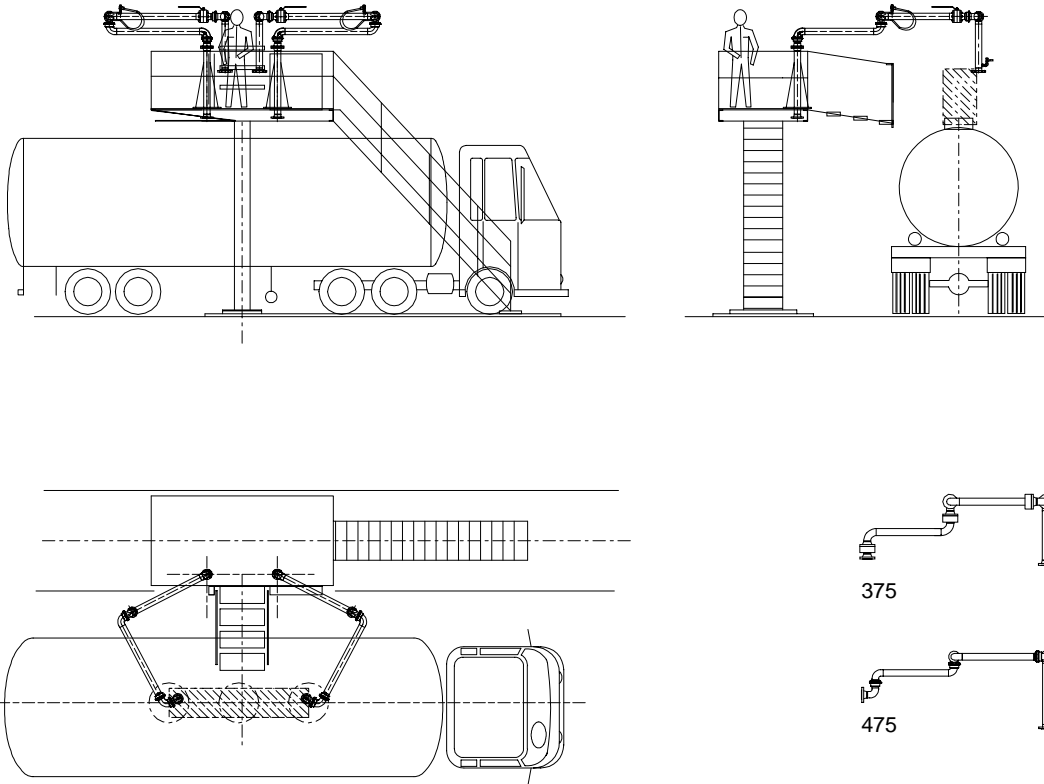

Closed system for top loading or unloading of trucks and railcars. This arm has the same features and capabilities as the top - open dome - Model 374. It offers the maximum amount of horizontal operating range and flexibility for handling mis-spotted vehicles where overhead obstructions are a consideration. The primary arm and secondary arm fold back to the rack for storage.

The addition of a style 50 swivel joint on the outboard arm gives two planes of rotation for maximum ease of alignment of a coupling device to the vehicle for unloading or loading.

Model 371 / 471

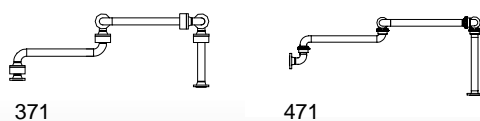

Same as the Model 375, but terminates with a style 10 instead of a style 50 swivel joint, giving an additional degree of freedom.